

Characteristics

Nominal Voltage		12V
Nominal Capacity (10 hour rate)		150Ah
Capacity 25°C(77°F)	10 hour rate (15.0A)	150Ah
	3 hour rate (37.5A)	112.5Ah
	1 hour rate (82.5A)	82.5Ah
Internal Resistance	Full Charged Battery 25°C(77°F)	≤8mΩ
Cyclic Life	50%(C ₁₀) Depth of discharge	700Times
Float Life	25°C(77°F) Float charge at 13.8V	About 5 Years
Capacity affected by Temperature (10 hour)	40°C (104°F)	102%
	25°C (77°F)	100%
	0°C (32°F)	85%
	-15°C (5°F)	65%
Self-Discharge 25°C(77°F)	Capacity after 3 month storage	90%
	Capacity after 6 month storage	80%
	Capacity after 12 month storage	62%
Charge (Constant Voltage) 25°C (77°F)	Cycle	Initial Charging Current Less than 45A Voltage 14.6-15.0V
	Float	Voltage 13.5-13.8V

Product Image



Packing

Battery (L×W×H)	mm ± 1	484×171×241
	inch	19.1×6.74×9.49
Box (L×W×H)	mm ± 2	507×194×312
	inch	20.0×7.64×12.3
Quantity Per Box		1 PCS
Net weight Per Cell		38.0 Kg ± 150g
Net weight Per Box		38.0 Kg
Gross Weight		38.5 Kg

Discharge Curve

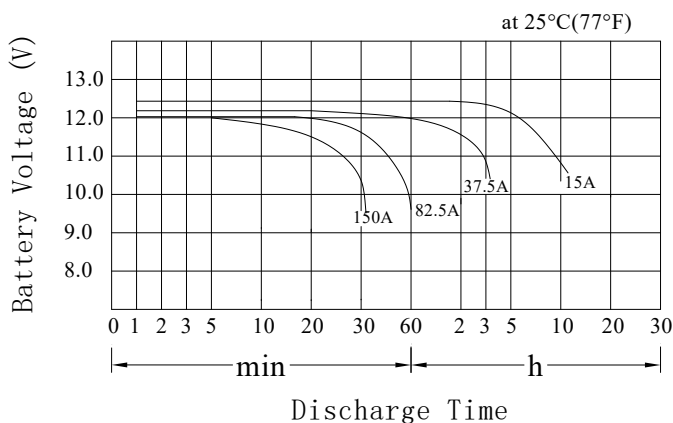

Product Dimensions

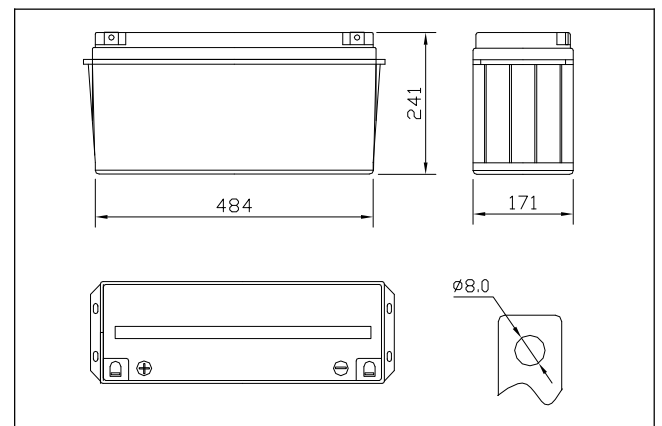

Battery Construction

Component	Positive plate	Negative plate	Container	Safety valve	Terminal	Separator	Electrolyte
Raw Material	Lead dioxide	Lead	ABS	Rubber	Pb	Fiberglass	Sulfuric acid

Discharge Characteristics

Voltage	Run Time (Constant Current and Power 25°C 77° F)										
	3 min	5 min	15 min	30 min	45 min	1h	2h	3h	5h	8h	10h
9.6 V	6555	5700	3225	2070	1545	1119	630	473	315	210	186
10.2V	6300	4875	2895	1845	1485	1104	608	465	312	207	185
10.5V	5775	4620	2730	1680	1455	1086	585	458	308	204	182
10.8V	5280	4395	2370	1500	1410	1065	570	435	293	203	180