

Characteristics

Nominal Voltage		12V
Nominal Capacity (10 hour rate)		250Ah
Capacity 25°C(77°F)	10 hour rate (25.0A)	250Ah
	3 hour rate (62.5A)	187.5Ah
	1 hour rate (137.5A)	137.5Ah
Internal Resistance	Full Charged Battery 25°C(77°F)	≤5mΩ
Cyclic Life	50%(C ₁₀) Depth of discharge	700Times
Float Life	25°C(77°F) Float charge at 13.8V	About 5 Years
Capacity affected by Temperature (10 hour)	40°C (104°F)	102%
	25°C (77°F)	100%
	0°C (32°F)	85%
	-15°C (5°F)	65%
Self-Discharge 25°C(77°F)	Capacity after 3 month storage	90%
	Capacity after 6 month storage	80%
	Capacity after 12 month storage	62%
Charge (Constant Voltage) 25°C (77°F)	Cycle	Initial Charging Current Less than 75A Voltage 14.6-15.0V
	Float	Voltage 13.5-13.8V

Product Image



Packing

Battery (L×W×H)	mm ± 1	520×268×245
	inch	20.5×10.6×9.8
Box (L×W×H)	mm ± 2	545×292×296
	inch	21.5×11.5×11.6
Quantity Per Box		1 PCS
Net weight Per Cell		65 Kg ± 200g
Net weight Per Box		65Kg
Gross Weight		65.5 Kg

Discharge Curve

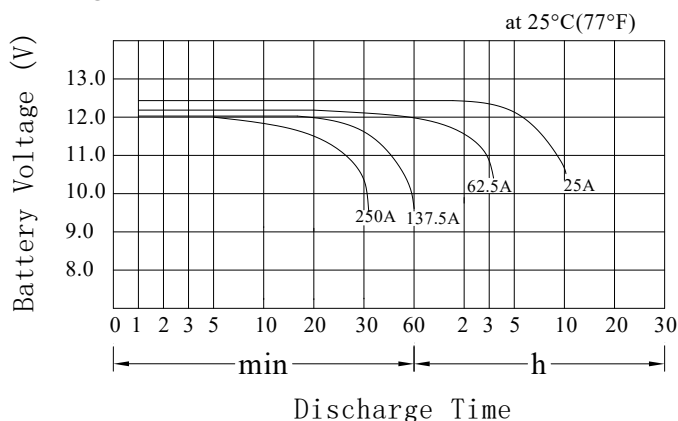

Product Dimensions

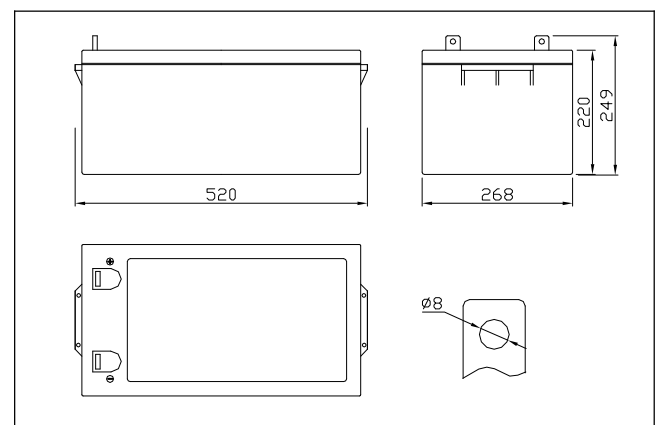

Battery Construction

Component	Positive plate	Negative plate	Container	Safety valve	Terminal	Separator	Electrolyte
Raw Material	Lead dioxide	Lead	ABS	Rubber	Pb	Fiberglass	Sulfuric acid

Discharge Characteristics

Voltage	Run Time (Constant Current and Power 25°C 77° F)										
	3 min	5 min	15 min	30 min	45 min	1h	2h	3h	5h	8h	10h
9.6 V	10925	9500	5375	3450	2575	1865	1050	788	525	350	310
10.2V	10500	8125	4825	3075	2475	1840	1013	775	520	345	308
10.5V	9625	7700	4550	2800	2425	1810	975	763	513	340	303
10.8V	8800	7325	3950	2500	2350	1775	950	725	488	338	300